

## New Author, New Techniques Lie Ahead at Tech Talk

**A**s professional security systems integrator and installer, what gets you excited? I know with me it can be something as simple a new idea. As we all know, installation and service time has been, and always will be, one of the most critical factors in the security systems business. Technicians are constantly under pressure to get the job done in a correct and professional manner.

It is the goal of this column, and my personal goal, to provide the systems professional with independent ideas and information that can immediately be used on the job.

As a “Tech Talk” reader, you can do more than just sit back and watch. If you have tried a new product or concept, used a new service, or tried an installation technique — good or bad — let me know. We all benefit from good communications and I am dependent on your feedback.

### Customizing Supervision of Security System Access

Shunting a secured opening is a valuable option in any installers bag of tricks. In this case, I want to provide simple, independent control over

a 24-hour zone to one or several doors, windows, etc. That sounds simple enough. If I provide a box with a push-button or key type switch, which will, on demand, short out the door contacts or motion sensors, then my problem is solved, right?

Close, but no cigar. One very important concept was overlooked — *operator supervision*. We often talk about alarm circuit supervision using techniques such as end-of-line (EOL) resistors, but what about supervising the user’s actions? What happens if the access point is shunted and forgotten about? You will probably next hear about an intrusion *miss* from the customers attorney.

The first application is a supervised shunt switch; see Diagram 1. This configuration will indicate when an access zone has been locally shunted. Further, it will protect the alarm system from being armed while the shunt is activated. Notice in Diagram 1 that the backside of a double pole, double throw (DPDT) switch is used for this shunting action. A physical security interlock is provided by the mechanical swinging action of the switch. When the switch is set to “on”

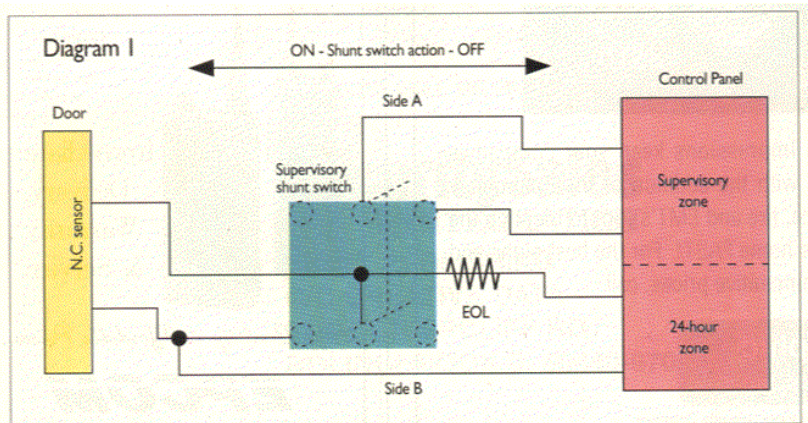

**This diagram shows how a supervised shunt switch will indicate to an alarm panel that an access zone has been locally bypassed. Plus, the shunt will protect the alarm from being armed while it is active.**



Bob Dolph has served in various technical management and advisory positions in the security industry for 25 years. Bob currently is a training and products consultant for the security industry. He lives in Orlando, Fla.

### BOB'S TIPS

- Use a shunt switch to prevent the system from arming until the user returns the shunt switch to the secure position. A shunt switch will not allow a system to be armed until the user returns it to the secure position.
- To operate the shunt properly, the user must turn it on before the door is opened and turn it off after the door is closed.
- The avoid a short circuit supervisory alarm on the panel when shunting move the existing EOL resistor to the location between the shunt switch and the control panel. supply specification.

status, side B is shunting (shorting) the door alarm zone and, simultaneously, side A is opening up an alarm panel supervisory zone. The shunt switch will not allow the system to be armed until the user returns the shunt switch to the secure position. Additional switch or relay contacts could be added to sound a supervisory annunciator to a guard desk.

### Shunting Requires Proper Use of End-of-Line Resistors

To operate the shunt properly, the user must turn it on **BEFORE** the door is opened and turn it off **AFTER** the door is closed. I know that a technical person will understand this, however, to reduce false alarms, make sure that this is explained clearly to the users. An operating instructions label on the shunt cover might be considered. Be careful when shunting a circuit that is supervised with an end-of-line resistor. To avoid a supervisory alarm on the panel when

# Tech Talk

## With Bob Dolph

shunting. move the existing EOL resistor to a location between the shunt switch and the control panel (see *Diagram 1*).

### Add flexibility by Using a Time-Delay Shunt Switch

Hardware configuration for a supervised shunt can be as simple as wiring an RP-44 latching push-button shadow switch from Alarm Control ([www.alarmscontrols.com](http://www.alarmscontrols.com)).

Some may want the option of a time-delay type shunt switch, thereby allowing for independent egress. Due to the time-delay electronics, I would suggest looking at a manufactured standalone battery-operated unit. Some units that come to mind are the ES-101 from Net-Tech ([www.net-tech.com](http://www.net-tech.com)) and the 290-1 from GRI ([www.grisk.com](http://www.grisk.com)). These units come with egress delay adjustments of 15 wconds to 120 seconds and are powered by panel power or a long-life lithium battery. Let me know of any similar system supervision configurations that you have found to be helpful.

The next application (see *Diagram 2*) involves monitoring the status of a manual deadbolt lock. This simple configuration can be connected in many ways. You can connect the bolt status sensor to an alarm panel circuit in order to have the alarm system supervise the physical status of the deadbolt. This configuration would

not allow the system to be armed unless the deadbolt had been secured.

Another similar application for this deadbolt switch is to arm and disarm a security system via the deadbolt action. An alarm panel-maintained arm/disarm input option is needed to do this. The deadbolt action provides a physical system interlock between locking a door and arming a system.

To install this configuration, select a miniature, adjustable, recessed, pin-type plunger switch, such as a PB-2020 from GRI or the 3010 from Sentrol ([www.sentrol.com](http://www.sentrol.com)). If the end of the bolt shaft is wood, consider the GRI contact. For a metal-capped bolt shaft, drill a hole through the metal cap and mount one of the flanged-type pin switches.

### Combining a Shunt With a Deadbolt Requires Careful Adjustment

**IMPORTANT:** When adjusting the pin switch, make sure to turn the plunger screw far enough out so that the screw plunger fully engages the internal reed contact when the dead-bolt is thrown. Avoid a marginal “make/break” adjustment, which could cause false alarms. Adjusting the pin too far out may affect proper locking of the deadbolt. Measure your distances carefully before drilling and installing.

Another reported variation of the deadbolt supervision configuration is to drill out a cavity and tap a mounting screw hole in the end of the bolt. Recess mount a small circular rare earth magnet

in the cavity at the end of the bolt. Use a standard 3/8-inch recessed alarm contact at the end of the bolt shaft. This method would probably have to be done in a machine shop. Be careful, as some better dead-bolts are hardened steel.

### Know the New 2002 National Electrical Code Changes

There are a considerable number of changes in the 2002 National Electrical Code (NEC). Make sure to take some time and update your NEC code book ([www.nfpa.org](http://www.nfpa.org)). Areas to review:

- Revised numbering similar to NFPA documentation
- New definitions for AHJ and ground electrode (Article 100)
- GFI requirements for burglary and fire circuits (Article 210)
- Metric designators and trade sizes for conduit, tubing, etc. (Article 300)
- Abandoned cable (Article 725)
- Grounding for communication system (Article 800)

